



→ wa333 the vector

INFINITE BATHROOM SOLUTIONS

DESCRIPTION:

The Vector wall-faced toilet suite offers a contemporary look that delivers a unique 6 litre full flush, and 3 litre half flush. This product has a W.E.L.S government approved 3 star water efficiency rating.

COLOUR:

White only

SET-OUT DETAILS:

S-Trap 190mm recommended
Optional 80-190mm universal elbow available
P-Trap 180mm

INLET OPTIONS:

Bottom inlet RHS and LHS option

Note: Provisions have been made for stop valves to be fitted externally left or right

SEAT:

Heavy duty plastic seat and lid, with chrome brass hinges incorporating a soft close mechanism

FIXATION/BRACKETS:

Floor brackets and screws are supplied as standard to secure toilet pan to the floor in preference to mortar bead

INSTALLATION:

Utilising supplied floor mount brackets with an appropriate silicon seal is recommended

PACKAGING:

Two cartons

WEIGHT:

55kg combined weight

WARRANTY:

Ceramic 10 years
Internal Parts 3 years
Seat and Lid 1 year

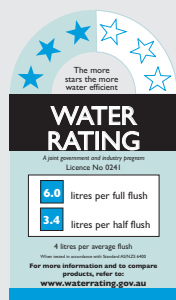

WaterMark
AS1172.1/AS1172.2
LN.21183
SAI Global

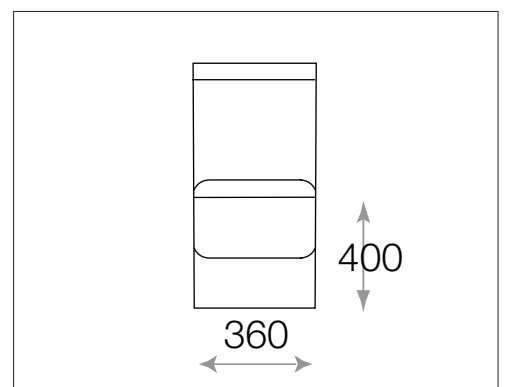
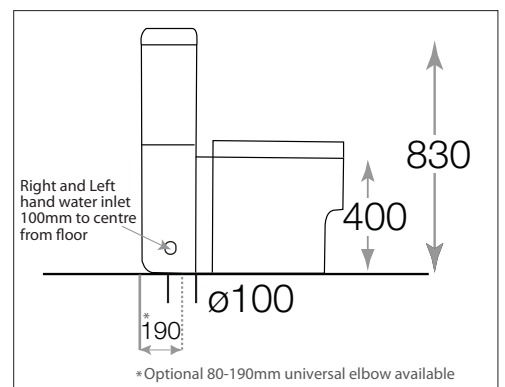
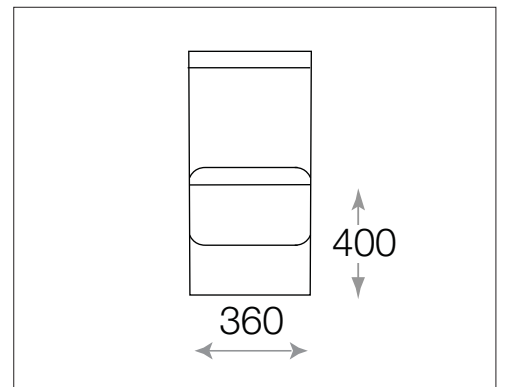
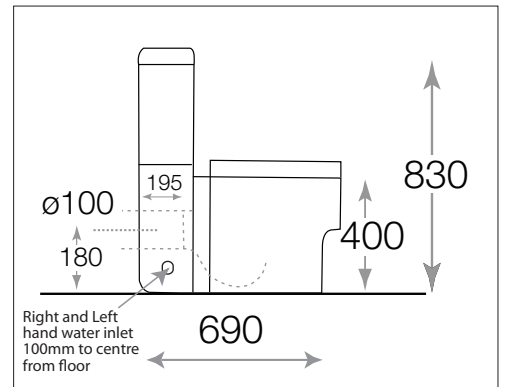

NOTE: All dimensions are in millimetres and are subject to standard manufacturing variations. Infinite Supplies Pty Ltd reserves the right to change any or all specifications without prior notice. Tolerance ± 5% for below 200mm, and ± 3% for above 200mm